

Snoelen & Associates

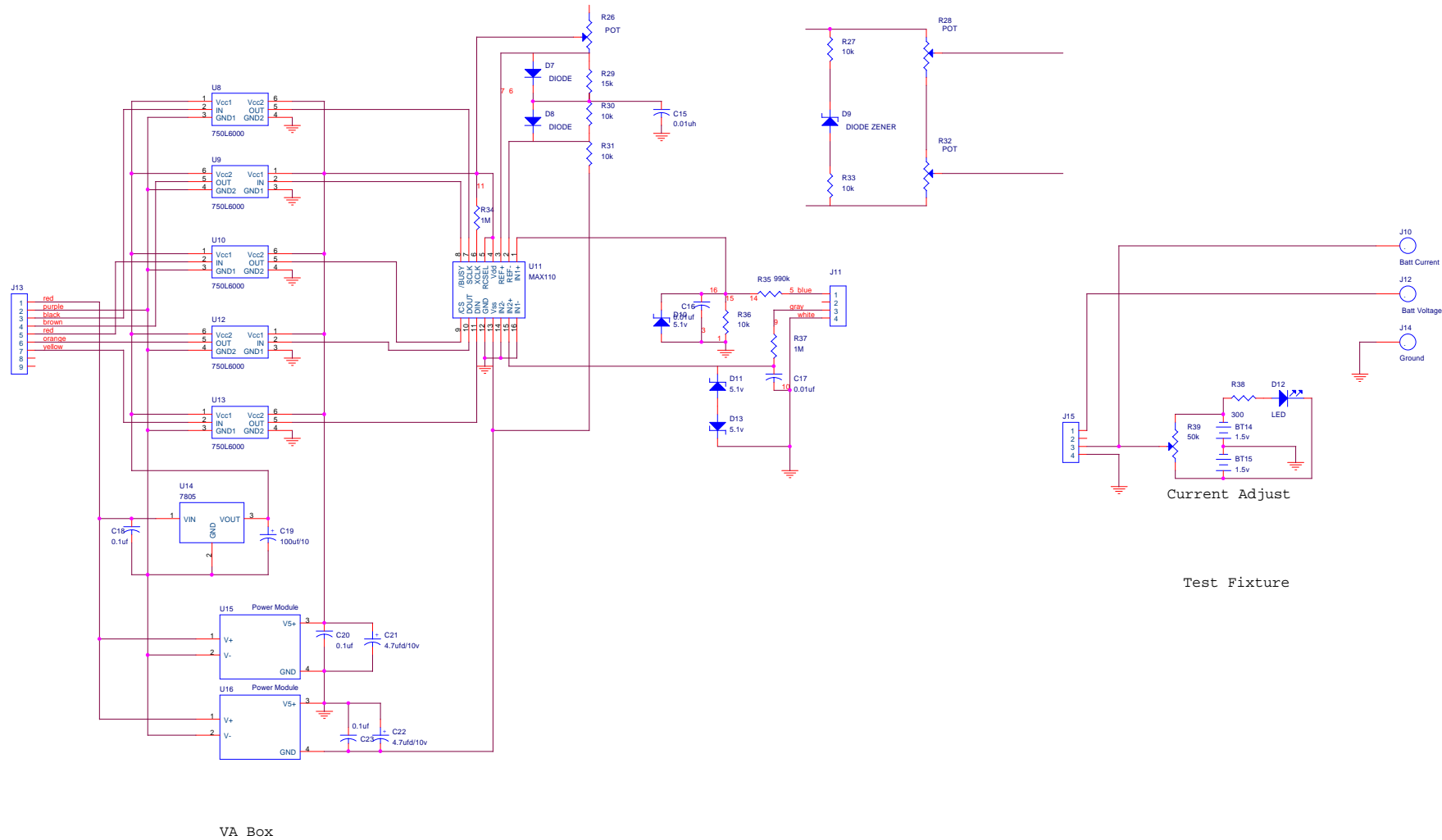

Current Adjust

Test Fixture

VA Box

| | | | |
|---------------------------------------|--|-------------------------------|---------|
| Snoblen & Associates | | | |
| Title: ECAR - VA Box And Test Fixture | | | |
| Size C | Document Number Design by Tom Snoblen | Copyright 2000 by Tom Snoblen | Rev 1.0 |
| Date: | Tuesday, June 13, 2000 | Sheet 3 | of 3 |